

# SSANGYONG SERVICE RECORD

**Internal Combustion Engines Vehicles**



**SSANGYONG**

5-YEAR WARRANTY

# Taking a SsangYong Service Plan will give you peace of mind

from just £10.99 per month inc VAT

SsangYong service plans have been specifically designed by SsangYong Motor UK Ltd to help our customers fight raising inflation by spreading the cost of their vehicle's annual maintenance over a fixed term with easy to manage monthly payments.

Service plans are available to all new and used SsangYong vehicles. New vehicle plans are available from date of registration up until 3months old.

New vehicle Service plan benefits:

- Fixed price cost (at today's prices to fight inflation)
- Extended RAC roadside assistance with limited replacement car hire
- One free MOT

To find out more please ask your local SsangYong dealership or visit:

<https://www.ssangyonggb.co.uk/pages/ownership/service-plans>

## PEACE OF MIND MOTORING

You receive more than just a vehicle when you took delivery of your new SsangYong. You received a comprehensive aftersales package to fulfil our peace of mind promise. This booklet explains how we deliver this promise and what you need to do in return.

## ABOUT THIS BOOKLET

This booklet is a valuable record of the services carried out on your SsangYong. Keeping this up-to-date with regular and timely servicing will help to enhance the value of your vehicle if you decide to sell it.

Please take care of this booklet as it cannot be easily replaced.

SsangYong Motor UK Ltd.

Tel: 0333 444 1954

[www.ssangyonggb.co.uk](http://www.ssangyonggb.co.uk)

## SsangYong Emergency Numbers

UK including NI Freephone: 0333 070 2694

Europe: 0033 472 43 52 55

Other useful telephone numbers:

.....

.....

.....

Your SsangYong Dealer

\* Not free from a mobile phone

## CONTENTS

### WARRANTY AND SERVICE INFORMATION

5	Vehicle Data
6	Welcome
7	SsangYong Assistance
8	New Vehicle Warranty
13	Travelling Abroad
14	Important Safety Information

### MAINTAINING YOUR SSANGYONG

18	Scheduled Maintenance
19	Weekly Check-Up
20	Maintenance Record
30	Additional Maintenance Record
32	Annual Body Inspection
39	Change of Address and Ownership
45	Notes

Date of revision – 01/01/2023

## VEHICLE DATA

Model: \_\_\_\_\_

VIN: \_\_\_\_\_

Engine No: \_\_\_\_\_

Registration No: \_\_\_\_\_

Warranty Start Date: \_\_\_\_\_

Colour Code: \_\_\_\_\_

Signature of Dealer representative

Dealer Stamp

THIS VEHICLE HAS A SERVICE FREQUENCY OF:

..... Miles

Or

12 Months

Whichever comes first

### Manufacturer's maintenance schedules

Diesel vehicles - 12 months or 12,500 miles (*whichever comes first*)

Petrol vehicles - 12 months or 10,000 miles (*whichever comes first*)

## WELCOME

... to the SsangYong family of owners and thank you for choosing a new SsangYong vehicle from the many on the market. We look forward to demonstrating our commitment to Customer Service during the ownership of your SsangYong.

Warranty - As the owner of a SsangYong vehicle you are entitled to a set period of time and mileage of comprehensive warranty cover, which starts from the date of registration. If you have any questions about your warranty cover, your responsibilities, or the aftersales benefits, please call us on 0333 444 1954.

SsangYong Assistance - With your new SsangYong you get the added peace of mind for 12 months SsangYong Assistance cover. You will find details of the cover provided on the following pages.

## SSANGYONG ASSISTANCE

Welcome to SsangYong Assistance. SsangYong has joined forces with the RAC, one of the UK's leading breakdown assistance organisations, to bring you SsangYong Assistance. Our roadside assistance package, available 24 hours a day, every day of the year.

### Who is covered by SsangYong Assistance?

SsangYong Assistance is vehicle based so it protects anyone driving your SsangYong with your permission. All new vehicles supplied by SsangYong in the UK are automatically covered by SsangYong Assistance, which provides cover for a period of 12 months from the date of first registration. The cover is applicable to the UK and Europe for the full 12 months.

If you sell the vehicle within this period, the new owner can take advantage of the remaining period of SsangYong Assistance until the vehicle's first birthday.

## HOW TO CALL SSANGYONG ASSISTANCE

1. In the event of requiring breakdown assistance in the UK please call: 0333 070 2694 or in Europe 0033 472 43 52 55\*

2. You will be asked to provide the following information:

- Your name
- A contact telephone number
- Your address
- The registration, model, and colour of your vehicle
- The nature of the breakdown
- Your exact location

- If you believe you are in a vulnerable or dangerous situation, please make this clear at the time of your call.

- After making the call return to a safe place near your vehicle.

For full details of your SsangYong Assistance cover and details of how to claim for European benefits please consult the SsangYong Assistance leaflet supplied with your vehicle.

\* Not free from a mobile phone

## NEW ICE VEHICLE WARRANTY

Our warranty covers parts failing due to faults in materials and workmanship at the time of manufacture. Under this warranty we will repair or replace any parts of a new SsangYong which are found to have such faults when the vehicle is used in normal conditions. You will not have to pay for any warranty repairs.

This warranty does not affect your statutory rights. The following conditions apply to this warranty.

1. Warranty Period - The warranty period begins on the date of first registration. The date the warranty ends depends on the type of warranty as shown below:

- **New Petrol and Diesel Vehicle Warranty** - All new ICE SsangYong vehicles sold in the UK are supplied with a warranty that covers faulty parts, materials, or workmanship at the time of manufacture subject to the conditions of Limited Coverage. All new ICE vehicles are covered by a five year or 100,000-mile warranty (whichever occurs first).
- **Anti-Perforation Warranty** - All new SsangYong vehicles sold in the UK have an anti-perforation warranty which covers holes in body panels caused by rust. It does not cover surface rust (caused by stone chips or scratches in the paint) or rust on any other part of the alloy wheels or vehicle, such as the exhaust system. This warranty lasts for six years.
- **Paintwork and Wheel Warranty** - All new SsangYong vehicles sold in the UK have a paint surface warranty which covers faulty paintwork at the time of manufacture. This warranty covers any problems with the paintwork and lacquer which happen through normal use and are caused by faulty material or workmanship. The warranty does not cover damage caused by stone chips, scratches, industrial fall out, chemicals etc. This warranty lasts for:
  - Vehicle paintwork - Three years or 60,000 miles, whichever occurs first.
  - Alloy wheel paint/lacquer - Three years or 37,500 miles, whichever occurs first.
- **Retail Parts Warranty** - All SsangYong parts and accessories are covered for 12 months. This warranty starts on the date you buy the part or accessory. This warranty does not cover parts and accessories unless they have been supplied and approved by SsangYong. *\*This does not apply to parts fitted under warranty which carry the balance of the new vehicle warranty\*.*
- **Accessory Part Warranty** - All accessories supplied or fitted to your vehicle are covered for 2 years or 25,000 miles from the date of purchase or fitment.



2. What is covered - A SsangYong Authorised Repairer will repair or replace faulty SsangYong parts within the warranty period. You will not have to pay with the following exceptions:

1. Glass - Covered for three months or 2,000 miles, whichever comes first
2. 12v Batteries - Covered for 2 years or 25,000 miles whichever comes first
3. Wheel alignment - Covered for three months or 2,000 miles, whichever comes first
4. Clutch components and brake discs - Covered for one year or 12,000 miles whichever comes first
5. Plus, the components listed in the Limited Coverage table on page 13 of this guide book

3. What is not covered - The SsangYong warranties do not cover the following:

- Damage, faults, or failure caused by:
  - an accident or another external cause.
  - misuse or neglect.
  - repairs not carried to the manufacturer's standards
  - fitting parts or accessories that have not been approved by SsangYong.

- using any fuel or fluids other than those recommended for the vehicle.
- altering the vehicle from the specification at manufacture; or
- environmental conditions such as industrial fallout, salt and storm damage

Additionally, SsangYong will not cover the cost of repairs relating to:

- Normal wear and tear, such as suspension links, ball joints and parts worn by normal driver usage and parts normally replaced or adjusted as part of the SsangYong service schedule
- Any vehicle on which the mileage has been changed or on which the actual mileage cannot be verified
- Any vehicle that has been used for racing, rallying or other competitive purposes
- Any vehicle for which you cannot provide proof of warranty cover
- Indirect loss and expenses such as loss of use, hotel costs, vehicle rental, other travel costs and loss of pay
- Towing charges

We may change the cars we produce. This does not mean that we must make similar changes to cars we have already produced

4. Tyre Warranty - The tyres fitted on new SsangYong vehicles are guaranteed by the tyre manufacturers.
5. Transferring your Warranty - If you buy a used SsangYong car, any remaining period of the new car warranty will be transferred to you, see elsewhere in this booklet.
6. Our Responsibilities - We will repair manufacturing faults free of charge during the warranty period. Please remember the difference between 'faults' and 'damage'. Faults are covered because as the manufacturer we are responsible, natural wear and tear is not covered under our vehicle warranty.
7. Your Responsibilities - We have no control over damage caused by things like a crash, misuse, and poor maintenance. Repairs of this nature are your responsibility. The warranty does not cover damage which happens after the vehicle is delivered to you.
8. Anti-Perforation (rust-through) Warranty - The anti-perforation warranty covers holes in body panels caused by rust. This warranty lasts for six years. It does not cover surface rust (caused by stone chips or scratches in the paint or lacquer for example) or rust on the exhaust system. The following conditions apply to this warranty and are your responsibility.

- You must have the vehicle inspected once a year by a SsangYong Authorised Repairer. The inspection will be recorded by the Dealer at the time it is carried out
- If your SsangYong Authorised Repairer tells you that the paintwork or body or wheels of the vehicle is damaged, you must arrange and pay for any necessary work
- If your SsangYong Authorised Repairer tells you that the paintwork or body of the vehicle is damaged, you must arrange and pay for any necessary work

Any paint or bodywork repairs must be carried out using our approved repair methods.

9. Vehicle Alteration - Your warranty does not cover alterations to the vehicle or failure of parts caused by alterations. For example, the warranty does not cover accessories such as sunroofs, towbars, and air conditioning systems, unless they have been approved and fitted by SsangYong.

10. Servicing and Maintenance - You are responsible for maintaining your vehicle and for having it serviced. You must keep proof that your vehicle has been properly maintained. Evidence of the Service and Maintenance history may be requested in the form of service invoices and additionally the service operation check sheets signed by the garage. If your vehicle is presented to a SsangYong Authorised Repairer for warranty related repairs.

The manufacturer's warranty will not provide cover if any fault is the result of poor maintenance. We strongly recommend that maintenance and servicing should be carried out by a SsangYong Authorised Repairer using genuine SsangYong parts and recommended lubricants.

This booklet enables you to record the service history.

We acknowledge that it is not always possible to carry out routine maintenance exactly on the date and mileage due. Because of this SsangYong allow a maximum window of 1000 miles or 1 month after the due date, however this cannot occur regularly, and vehicles maintained outside of these criteria may invalidate parts of their warranty.

The vehicles SRS Air Bag system needs to be inspected every 10 years or 125,000 miles and replaced if any abnormalities are present.

During Harsh conditions (please refer to your owner's manual under scheduled vehicle maintenance) your vehicle may need more frequent service checks and maintenance, especially items such as Automatic transmission fluids and 4x4 axle fluids. Please refer to your owner's manual for further guidance. Failure to adhere to this may affect the warranty cover on your vehicle.

This warranty is fully transferable should you sell your SsangYong to a private individual.

We are sure that you have many years and many miles of trouble free motoring with your SsangYong ahead.

If you have any further questions then please feel free to contact your local SsangYong dealer.

Component	Limit
Spark Plugs	Up to 1st Scheduled Change
Oil/Air/Fuel Filter/Pollen Filter	Up to 1st Scheduled Change
Auxiliary Drive Belts	12 Months / 12,500 Miles
Air Con re-gas (no evident defect)	12 Months / 12,500 Miles
Brake Linings and Discs	12 Months / 12,500 Miles
Clutch Disc	12 Months / 12,500 Miles
Wiper Blades	12 Months / 12,500 Miles
Fuses	12 Months / 12,500 Miles
Adjustments	3 Months / 2,000 Miles
Glass	3 Months / 2,000 Miles
Bulbs & Lamp Filaments	12 Months / 12,500 Miles
Bi-Xenon Bulbs	12 Months / 12,500 Miles
Wheel Bearings	60 Months / 60,000 Miles
Ball Joints	60 Months / 60,000 Miles
Suspension Bushes	60 Months / 60,000 Miles
Track Rod Ends	60 Months / 60,000 Miles
Dampers/Struts/Springs	60 Months / 60,000 Miles
All Rubber Components	60 Months / 60,000 Miles
Accessory Parts	24 Months
12v Batteries	24 Months / 25,000 Miles
Tyres	Warranty administered by the tyre company
Audio	60 Months
Alloy Wheels	36 Months / 37,500 Miles

The LIMITED COVERAGE table opposite indicates consumables and wear & tear items normally replaced in the process of routine maintenance and service protocols and where normal useful life of these components has expired.

For full terms and conditions of the SsangYong manufacturer's warranty, please refer to our website. [www.ssangyonggb.co.uk](http://www.ssangyonggb.co.uk)

## TRAVELLING ABROAD

Your warranty cover extends to Europe and you can have warranty work carried out in any EU member state, by an Authorised SsangYong dealer.

Should any circumstance arise where you are requested to pay for repairs that you wish to claim on your return to the UK under the terms of the SsangYong warranty you must gain approval prior to agreeing to the repairs.

You can gain approval by contacting -

SsangYong customer services on:  
customerservice@ssangyonggb.co.uk or telephone  
0333 444 1954 during normal business hours.

If you travel to Europe it is important that you take this booklet with you. It is proof that your car has warranty cover and that services have been carried out. Please make sure that your vehicle will not need servicing during your trip.

Make sure you are aware of any legal requirements in the countries you are traveling through. For example many European countries require that you carry a warning triangle and self breathalyser tests. Also some countries have strict laws on the fitting of bicycle racks and other accessories.

Your SsangYong Assistance cover provides service throughout Europe for the first 12 months for full details please consult the SsangYong Assistance leaflet supplied with your car.

After the first 12 months you will be given the opportunity to renew your SsangYong assistance cover.

Please be reminded that the vehicle warranty will not cover any recovery or associated costs.

When traveling abroad we recommend that you have extra insurance to cover unforeseen events.

## IMPORTANT SAFETY INFORMATION

Owner's Manual - It is important that you read the Owner's Manual supplied with your car. Apart from the normal day to day checks there is additional information which could affect the safety of you, your passengers and other road users. When you sell your car please make sure the Owner's Manual stays with the car for the next owner.

Please read your Owner's Manual carefully

Seat Belts - Seat belts must be worn at all times by you and any passengers in the car. Seat belts need inspecting from time to time to make sure they are not damaged. If your car has front seat belt pretensioners fitted they must be replaced if they have activated. In the event of an accident please make sure all seat belt components are checked by a SsangYong Authorised Repairer.

For full details on your seat belts refer to your Owner's Manual  
Supplementary Restraint System (SRS) - Your SsangYong is fitted with a Supplementary Restraint System (SRS). This system supplements the front seat belts and can provide additional protection for you in the event of an accident. In the event of an accident the system must be checked, and the airbags replaced if they have activated.

The SRS Sir Bag system needs to be regularly inspected every 10 years or 125,000 miles and replaced if any abnormalities are found to be present.

For full details on this system refer to your Owner's Manual.



# MAINTAINING YOUR SSANGYONG

---



## SCHEDULED MAINTENANCE

Regular maintenance is a major factor in prolonging the vehicle's life, sustained performance and trouble-free motoring. It also increases the potential in resale value. To help in achieving this, SsangYong has developed a plan of inspection and service operations to be carried out at given intervals.

It is very important that your vehicle is serviced at correct intervals, deviating from the intervals can invalidate parts of your warranty.

It is strongly recommended that the maintenance services are performed by a SsangYong Authorised Repairer who will have trained technicians and use genuine parts with which to maintain your vehicle properly.

If your vehicle only covers a low annual mileage, for example less than 5,000 miles, you must still have a service carried out every 12 months.

This is because the condition of your engine oil and other fluids will deteriorate if you only use your SsangYong for short journeys or infrequently. Other service items are dependent on time and not just mileage.

During harsh conditions (please refer to your owner's manual) your vehicle may need more frequent service checks and maintenance, especially items such as Automatic transmission fluids and 4x4 axle fluids, please refer to your owner's manual for further guidance. Failure to adhere to this may affect your vehicles warranty.

Periodically, as the time and mileage increases, your SsangYong Authorised Repairer will automatically undertake the additional work shown in the schedule.

In addition, routine inspections will include checks for outstanding service campaigns, safety recalls and software updates.

Inadequate, incomplete, or insufficient servicing may result in operational problems with your vehicle that could even lead to vehicle damage, an accident or personal injury.

Poor service history, incorrect maintenance or loss of service records may also result in the disqualification of the vehicle warranty.

## WEEKLY CHECK-UP

The following checks should be performed weekly to maintain safe and dependable operation. Check:

- Engine oil level
- Brake and clutch fluid
- Power steering fluid level
- Windscreen washer fluid level
- Operation of lights
- All switches
- Operation of handbrake
- Rear view mirrors
- Tyre pressures
- Check for damaged tyres

If your vehicle covers a very high mileage or is used in adverse conditions these checks should be performed more frequently.

For details on maintenance and operational checks refer to your Owner's Manual.

## SSANGYONG SERVICE PLANS

SsangYong service plans have been specifically designed by SsangYong Motor UK Ltd to help our customers spread the cost of their vehicle's annual maintenance over a fixed term with easy to manage monthly payments.

Service plans are available to all new and used SsangYong vehicles. New vehicle plans are available from date of registration up until 3 months old.

New vehicle Service plan benefits:

- Fixed price cost
- Extended RAC roadside assistance with limited replacement car hire
- One free MOT

To find out more please ask your local SsangYong dealership or visit:

<https://www.ssangyonggb.co.uk/pages/ownership/service-plans>

## 1<sup>st</sup> SERVICE

Date: \_\_\_\_\_

Mileage: \_\_\_\_\_

Job No: \_\_\_\_\_

Dealer Code: \_\_\_\_\_

Signature of Dealer representative

Dealer Stamp

## 2<sup>nd</sup> SERVICE

Date: \_\_\_\_\_

Mileage: \_\_\_\_\_

Job No: \_\_\_\_\_

Dealer Code: \_\_\_\_\_

Signature of Dealer representative

Dealer Stamp

### 3<sup>rd</sup> SERVICE

Date: \_\_\_\_\_

Mileage: \_\_\_\_\_

Job No: \_\_\_\_\_

Dealer Code: \_\_\_\_\_

Signature of Dealer representative

---

Dealer Stamp

### 4<sup>th</sup> SERVICE

Date: \_\_\_\_\_

Mileage: \_\_\_\_\_

Job No: \_\_\_\_\_

Dealer Code: \_\_\_\_\_

Signature of Dealer representative

---

Dealer Stamp

## 5<sup>th</sup> SERVICE

Date: \_\_\_\_\_

Mileage: \_\_\_\_\_

Job No: \_\_\_\_\_

Dealer Code: \_\_\_\_\_

Signature of Dealer representative

---

Dealer Stamp

## 6<sup>th</sup> SERVICE

Date: \_\_\_\_\_

Mileage: \_\_\_\_\_

Job No: \_\_\_\_\_

Dealer Code: \_\_\_\_\_

Signature of Dealer representative

---

Dealer Stamp

## 7<sup>th</sup> SERVICE

Date: \_\_\_\_\_

Mileage: \_\_\_\_\_

Job No: \_\_\_\_\_

Dealer Code: \_\_\_\_\_

Signature of Dealer representative

---

Dealer Stamp

## 8<sup>th</sup> SERVICE

Date: \_\_\_\_\_

Mileage: \_\_\_\_\_

Job No: \_\_\_\_\_

Dealer Code: \_\_\_\_\_

Signature of Dealer representative

---

Dealer Stamp

## 9<sup>th</sup> SERVICE

Date: \_\_\_\_\_

Mileage: \_\_\_\_\_

Job No: \_\_\_\_\_

Dealer Code: \_\_\_\_\_

Signature of Dealer representative

---

Dealer Stamp

## 10<sup>th</sup> SERVICE

Date: \_\_\_\_\_

Mileage: \_\_\_\_\_

Job No: \_\_\_\_\_

Dealer Code: \_\_\_\_\_

Signature of Dealer representative

---

Dealer Stamp

## 11<sup>th</sup> SERVICE

Date: \_\_\_\_\_

Mileage: \_\_\_\_\_

Job No: \_\_\_\_\_

Dealer Code: \_\_\_\_\_

Signature of Dealer representative

---

Dealer Stamp

## 12<sup>th</sup> SERVICE

Date: \_\_\_\_\_

Mileage: \_\_\_\_\_

Job No: \_\_\_\_\_

Dealer Code: \_\_\_\_\_

Signature of Dealer representative

---

Dealer Stamp



## 13<sup>th</sup> SERVICE

Date: \_\_\_\_\_

Mileage: \_\_\_\_\_

Job No: \_\_\_\_\_

Dealer Code: \_\_\_\_\_

Signature of Dealer representative

---

Dealer Stamp

## 14<sup>th</sup> SERVICE

Date: \_\_\_\_\_

Mileage: \_\_\_\_\_

Job No: \_\_\_\_\_

Dealer Code: \_\_\_\_\_

Signature of Dealer representative

---

Dealer Stamp

## 15<sup>th</sup> SERVICE

Date: \_\_\_\_\_

Mileage: \_\_\_\_\_

Job No: \_\_\_\_\_

Dealer Code: \_\_\_\_\_

Signature of Dealer representative

---

Dealer Stamp

## 16<sup>th</sup> SERVICE

Date: \_\_\_\_\_

Mileage: \_\_\_\_\_

Job No: \_\_\_\_\_

Dealer Code: \_\_\_\_\_

Signature of Dealer representative

---

Dealer Stamp

## 17<sup>th</sup> SERVICE

Date: \_\_\_\_\_

Mileage: \_\_\_\_\_

Job No: \_\_\_\_\_

Dealer Code: \_\_\_\_\_

Signature of Dealer representative

---

Dealer Stamp

## 18<sup>th</sup> SERVICE

Date: \_\_\_\_\_

Mileage: \_\_\_\_\_

Job No: \_\_\_\_\_

Dealer Code: \_\_\_\_\_

Signature of Dealer representative

---

Dealer Stamp

## 19<sup>th</sup> SERVICE

Date: \_\_\_\_\_

Mileage: \_\_\_\_\_

Job No: \_\_\_\_\_

Dealer Code: \_\_\_\_\_

Signature of Dealer representative

---

Dealer Stamp

## 20<sup>th</sup> SERVICE

Date: \_\_\_\_\_

Mileage: \_\_\_\_\_

Job No: \_\_\_\_\_

Dealer Code: \_\_\_\_\_

Signature of Dealer representative

---

Dealer Stamp

ADDITIONAL MAINTENANCE RECORD

### BRAKE FLUID CHANGE

Date due: \_\_\_\_\_

Mileage: \_\_\_\_\_

(Whichever comes first)

Carried out: \_\_\_\_\_

Date: \_\_\_\_\_

Mileage: \_\_\_\_\_

Dealer Code: \_\_\_\_\_

Signature of Dealer representative

Dealer Stamp

### BRAKE FLUID CHANGE

Date due: \_\_\_\_\_

Mileage: \_\_\_\_\_

(Whichever comes first)

Carried out: \_\_\_\_\_

Date: \_\_\_\_\_

Mileage: \_\_\_\_\_

Dealer Code: \_\_\_\_\_

Signature of Dealer representative

Dealer Stamp

ADDITIONAL MAINTENANCE RECORD

### BRAKE FLUID CHANGE

Date due: \_\_\_\_\_

Mileage: \_\_\_\_\_

(Whichever comes first)

Carried out: \_\_\_\_\_

Date: \_\_\_\_\_

Mileage: \_\_\_\_\_

Dealer Code: \_\_\_\_\_

Signature of Dealer representative

Dealer Stamp

### BRAKE FLUID CHANGE

Date due: \_\_\_\_\_

Mileage: \_\_\_\_\_

(Whichever comes first)

Carried out: \_\_\_\_\_

Date: \_\_\_\_\_

Mileage: \_\_\_\_\_

Dealer Code: \_\_\_\_\_

Signature of Dealer representative

Dealer Stamp

### 1. ANNUAL BODY & WHEEL INSPECTION

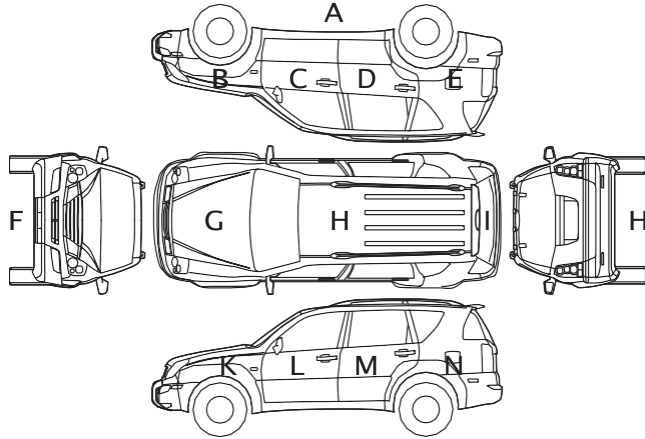

BODY: NO / YES

DAMAGED: ( ) ( )

AREA STONE CHIPPED: ( ) ( )

AREA DENTS: ( ) ( )

AREA SCRATCHES: ( ) ( )

AREA: ( ) ( )

( ) ( ) AREA PAINT OR BODYWORK YES ( ) NO ( )

REPAIRED BY:

INVOICE NO:

SIGNED:

DATE:

Dealer stamp

Any damage should be repaired as soon as possible to keep your warranty valid. Repairs must be carried out using our approved repair methods. For further information please refer to details elsewhere in this booklet.

## 2. ANNUAL BODY & WHEEL INSPECTION

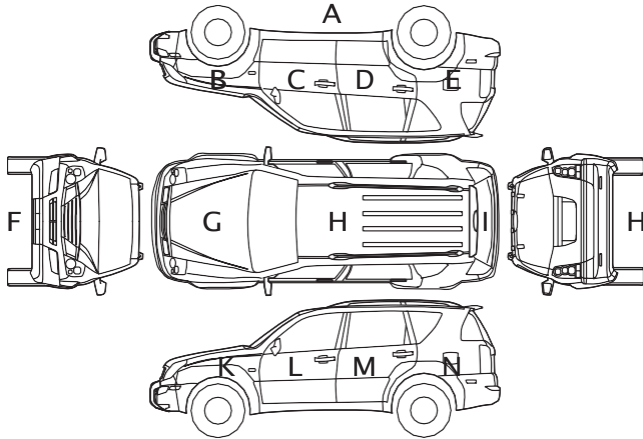

BODY: NO / YES

DAMAGED: ( ) ( )

AREA STONE CHIPPED: ( ) ( )

AREA DENTS: ( ) ( )

AREA SCRATCHES: ( ) ( )

AREA: ( ) ( )

( ) ( ) AREA PAINT OR BODYWORK YES ( ) NO ( )

REPAIRED BY:

INVOICE NO:

SIGNED:

DATE:

Dealer stamp

Any damage should be repaired as soon as possible to keep your warranty valid. Repairs must be carried out using our approved repair methods. For further information please refer to details elsewhere in this booklet.



## 3. ANNUAL BODY & WHEEL INSPECTION

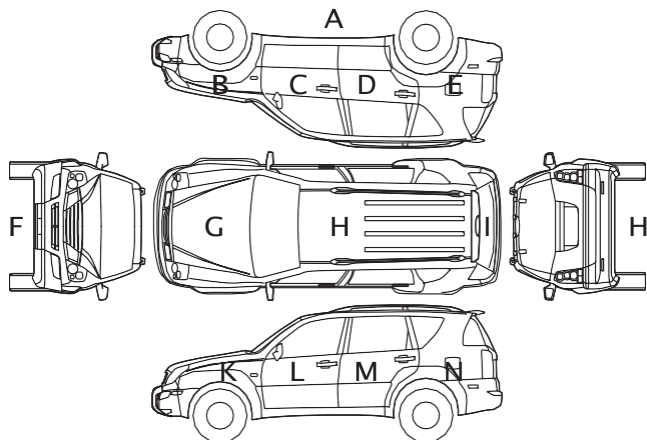

BODY: NO / YES

DAMAGED: ( ) ( )

AREA STONE CHIPPED: ( ) ( )

AREA DENTS: ( ) ( )

AREA SCRATCHES: ( ) ( )

AREA: ( ) ( )

( ) ( ) AREA PAINT OR BODYWORK YES ( ) NO ( )

REPAIRED BY:

INVOICE NO:

SIGNED:

DATE:

Dealer stamp

Any damage should be repaired as soon as possible to keep your warranty valid. Repairs must be carried out using our approved repair methods. For further information please refer to details elsewhere in this booklet.

4. ANNUAL BODY & WHEEL INSPECTION

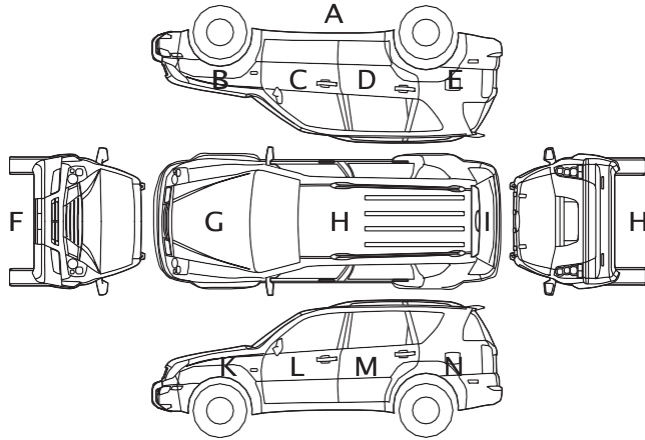

BODY: NO / YES

DAMAGED: ( ) ( )

AREA STONE CHIPPED: ( ) ( )

AREA DENTS: ( ) ( )

AREA SCRATCHES: ( ) ( )

AREA: ( ) ( )

( ) ( ) AREA PAINT OR BODYWORK YES ( ) NO ( )

REPAIRED BY:

INVOICE NO:

SIGNED:

DATE:

Dealer stamp

Any damage should be repaired as soon as possible to keep your warranty valid. Repairs must be carried out using our approved repair methods. For further information please refer to details elsewhere in this booklet.

## 5. ANNUAL BODY & WHEEL INSPECTION

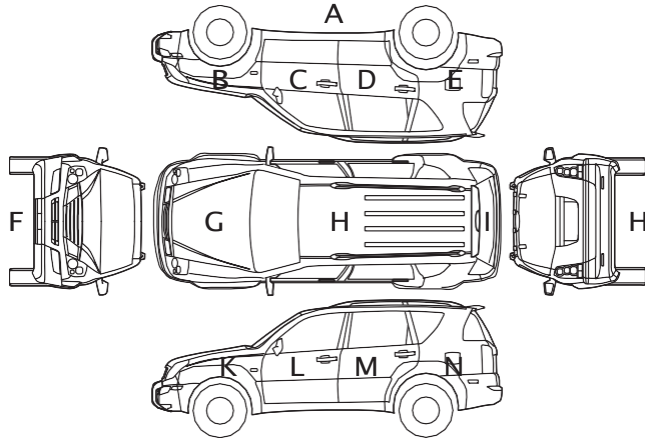

BODY: NO / YES

DAMAGED: ( ) ( )

AREA STONE CHIPPED: ( ) ( )

AREA DENTS: ( ) ( )

AREA SCRATCHES: ( ) ( )

AREA: ( ) ( )

( ) ( ) AREA PAINT OR BODYWORK YES ( ) NO ( )

REPAIRED BY:

INVOICE NO:

SIGNED:

DATE:

Dealer stamp

Any damage should be repaired as soon as possible to keep your warranty valid. Repairs must be carried out using our approved repair methods. For further information please refer to details elsewhere in this booklet.

## 6. ANNUAL BODY & WHEEL INSPECTION

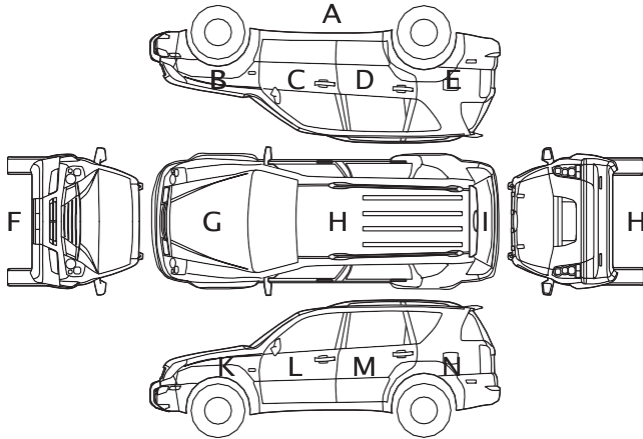

BODY: NO / YES

DAMAGED: ( ) ( )

AREA STONE CHIPPED: ( ) ( )

AREA DENTS: ( ) ( )

AREA SCRATCHES: ( ) ( )

AREA: ( ) ( )

( ) ( ) AREA PAINT OR BODYWORK YES ( ) NO ( )

REPAIRED BY:

INVOICE NO:

SIGNED:

DATE:

Dealer stamp

Any damage should be repaired as soon as possible to keep your warranty valid. Repairs must be carried out using our approved repair methods. For further information please refer to details elsewhere in this booklet.



## CHANGE OF OWNERSHIP

---

## CHANGE OF ADDRESS AND OWNERS

### Change of Address

It is important that you tell us if you change your address. This is to make sure we can contact you if there is a product update or recall on your car.

Please use the card in this booklet to tell us if you move.

### Change of Owner

If you bought this car privately or from a non-SsangYong garage please send us your name, address and car details. This is to make sure we can contact you if there is a product update or recall on your car.

Please use the card in this booklet to tell us if you are the new owner of this car. Alternatively, please send your details to:

SsangYong Motor UK Ltd  
PO Box 4287  
Parsonage Road,  
Swindon,  
SN2 9LT

**CHANGE OF OWNERSHIP / ADDRESS**

Registration Number:

VIN:

Name:

Address:

**SsangYong Emergency Numbers**

UK including NI Freephone: 0333 070 2694

Europe: 0033 472 43 52 55\*

Other useful telephone numbers:

.....  
.....  
.....

Your SsangYong Dealer

\* Not free from a mobile phone



Please fill in your information on the reverse of this page, cut out and send in an envelope to the following address.

SsangYong Motor UK Ltd  
PO Box 4287  
Parsonage Road,  
Swindon,  
SN2 9LT

**CHANGE OF OWNERSHIP / ADDRESS**

Registration Number:

VIN:

Name:

Address:

**SsangYong Emergency Numbers**

UK including NI Freephone: 0333 070 2694

Europe: 0033 472 5255\*

Other useful telephone numbers:

.....  
.....  
.....

Your SsangYong Dealer

\* Not free from a mobile phone

Please fill in your information on the reverse of this page, cut out and send in an envelope to the following address.

SsangYong Motor UK Ltd  
PO Box 4287  
Parsonage Road,  
Swindon,  
SN2 9LT

## NOTES

.....

.....

.....

.....

.....

.....

.....

.....

.....

.....

.....

.....

.....

.....

.....

.....

.....

.....

.....

.....

.....

.....

.....

.....

.....

.....

.....

.....

.....

.....

.....

.....

.....

.....

.....

.....

.....

.....

.....

.....

.....

.....

.....

.....

.....

## NOTES

---

---

---

---

---

---

---

---

---

---

---

---

---

---

---

---

---

---

---

---

---

---

---

---

---

---

---

---

---

---

---

---

---

---

---

---

---

---

---

---

---

---

---

---

---

---

---

---

---

---

---

---

---

---

---

---

---

---

---

---





**SSANGYONG**

5-YEAR WARRANTY

SER0023-5YR